

## 1" DIAPHRAGM PUMP 1:1 RATIO (METALLIC)



**READ THIS MANUAL CAREFULLY BEFORE INSTALLING, OPERATING OR SERVICING THIS EQUIPMENT.**

It is the responsibility of the employer to place this information in the hands of the operator. Keep for future reference.

### SERVICE KITS

Refer to "Model Description Chart" to match the pump material options.

- DP31-Air25** for Air Section repair (see page 8).
- DP31-Flu25-XXX** for fluid section repair with seats (see page 4).
- DP31-Flu25-XX** for fluid section repair without seats (see page 4).

### PUMP DATA

- Models** . . . . . see Model Description Chart for "-XXXXXX".
  - Pump Type** . . . . . Metallic, Air Operated, Double Diaphragm
  - Material** . . . . . see Model Description Chart
  - Weight** . . . . . Aluminum ,19 LBS(8.6 kgs)  
Stainless Steel ,36 LBS(16.3 kgs)  
Cast Iron ,31 LBS(14.1kgs)
  - Maximum Air Inlet Pressure** . . . . . 120 p.s.i. (8.3 bar)
  - Maximum Material Inlet Pressure** . . . . . 10 p.s.i. (0.69 bar)
  - Maximum Outlet Pressure** . . . . . 120 p.s.i. (8.3 bar)
  - Maximum Flow Rate ( flooded inlet)** . . . . . 36 gpm (136 lpm)
  - Displacement / Cycle @100p.s.i**  
Standard Diaphragm. . . . . 0.17 gal (.64 lit)
  - Maximum Particle Size (semi-solids)** . . . . .1/8" dia. (3.2 mm)
  - Maximum Temperature Limits**  
Polypropylene . . . . . 35° to 175° F (2° to 79° C)  
PVDF (Kynar) . . . . . 10° to 200° F (-12° to 93° C)
  - Dimensional Data** . . . . . see page 8
  - Noise Level @ 70 p.s.i. - 60 cpm** . . . . . 64.5 dB(A)
- NOTICE:** All possible options are shown in the chart, however, certain combinations may not be recommended, consult a representative or the factory if you have questions concerning availability.

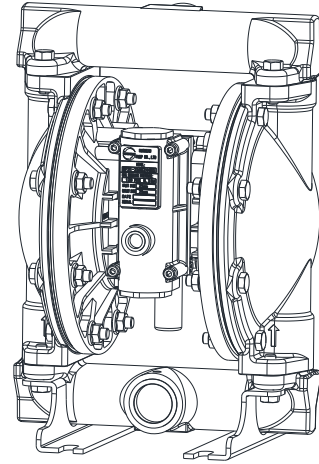

Figure 1

### GENERAL DESCRIPTION

Our Diaphragm Pump offers high volume delivery even at low air pressures and a broad range of material compatibility options available. Refer to the model and option chart. Our pumps features stall-resistant design, maintenance-free air motor with a long lifespan, modular air motor/ fluid sections. Air Operated diaphragm pumps utilize a pressure differential in the air chambers to alternately create suction and positive fluid pressure in the fluid chambers, ball checks insure a positive flow of fluid. Pump cycling will begin as air pressure is applied and it will continue to pump and keep up with the demand. It will build and maintain line pressure and will stop cycling once maximum line pressure is reached(dispensing device closed) and will resume pumping as needed.

### ◆ MODEL DESCRIPTIONS & ORDERING :

DP31	-	25	X	X	X	X	X	X	X
		Pump Size	Center Body Mat.	Fluid Caps Manifold Mat.	Seat Material	Ball Check Material	Diaphragm Material	Fluid Connections	Hardware

Pump Size	25-1"								
Center Body Mat.	A-Aluminum				C-Cast Iron				
Fluid Caps Manifold Mat.	A - Aluminum				S -Stainless Steel		C-Cast Iron		
Seat Material	1 - Aluminum		2 - 316 Stainless Steel		3-Polypropylene		4-PVDF(Kynar)		
	5-Carbon Steel		8-Hard 400 Stainless Steel						
Ball Check Material	1-Neoprene		2-Nitrile		3-Viton		4-PTFE		
	5-E.P.R		6-Acetal		8-Polyurethane		A-Stainless Steel		
	C-Hytrel				E-Santoprene				
Diaphragm Material	1-Neoprene		2-Nitrile		3-Viton		4-PTFE/Santoprene		
	5-E.P.R		6-Acetal		9-Hytrel		B-Santoprene		
	G-Nitrile								
Fluid Connections	N-NPT Threads				B-BSP Threads				
Hardware	S-Stainless Steel				C-Carbon Steel				

#### Service Repair Kits:

- DP31-Air25(air section)
- DP31-Flu25 - XX(fluid section)

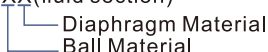

## OPERATING AND SAFETY PRECAUTIONS

READ, UNDERSTAND, AND FOLLOW THIS INFORMATION TO AVOID INJURY AND PROPERTY DAMAGE.



**⚠ WARNING** EXCESSIVE AIR PRESSURE. Can cause personal injury, pump damage or property damage.

- Be sure material hoses and other components are able to withstand fluid pressures developed by this pump. Check all hoses for damage or wear. Be certain dispensing device is clean and in proper working condition.
- Do not exceed the maximum inlet air pressure as stated on the pump model plate.

**⚠ WARNING** STATIC SPARK. Can cause explosion resulting in severe injury or death. Ground pump and pumping system.

- Sparks can ignite flammable material and vapors.
- The pumping system and object being sprayed must be grounded when it is pumping, flushing, recirculating or spraying flammable materials such as paints, solvents, lacquers, etc. or used in a location where surrounding atmosphere is conductive to spontaneous combustion. Ground the dispensing valve or device, containers, hoses and any object to which material is being pumped.
- Secure pump, connections and all contact points to avoid vibration and generation of contact or static spark.
- Consult local building codes and electrical codes for specific grounding requirements.
- After grounding, periodically verify continuity of electrical path to ground. Test with an ohmmeter from each component (e.g., hoses, pump, clamps, container, spray gun, etc.) to ground to insure continuity. Ohmmeter should show 0.1 ohms or less.
- Submerge the outlet hose end, dispensing valve or device in the material being dispensed if possible. (Avoid free streaming of material being dispensed.)
- Use hoses incorporating a static wire.
- Use proper ventilation.
- Keep inflammables away from heat, open flames and sparks.
- Keep containers closed when not in use.

**⚠ WARNING** Pump exhaust may contain contaminants. Can cause severe injury. Pipe exhaust away from work area and personnel.

- In the event of a diaphragm rupture, material can be forced out of the air exhaust muffler.
- Pipe the exhaust to a safe remote location when pumping hazardous or inflammable materials.
- Use a grounded 3/8 minimum i.d. hose between the pump and the muffler.

**⚠ WARNING** HAZARDOUS PRESSURE. Can result in serious injury or property damage. Do not service or clean pump, hoses or dispensing valve while the system is pressurized.

- Disconnect air supply line and relieve pressure from the system by opening dispensing valve or device and / or carefully and slowly loosening and removing outlet hose or piping from pump.

**⚠ WARNING** HAZARDOUS MATERIALS. Can cause serious injury or property damage. Do not attempt to return a pump to the factory or service center that contains hazardous material. Safe handling practices must comply with local and national laws and safety code requirements.

- Obtain Material Safety Data Sheets on all materials from the supplier for proper handling instructions.

**⚠ WARNING** EXPLOSION HAZARD. Models containing aluminum wetted parts cannot be used with 1,1,1-trichloroethane, methylene chloride or other halogenated hydrocarbon solvents which may react and explode.

- Check pump motor section, fluid caps, manifolds and all wetted parts to assure compatibility before using with solvents of this type.

**⚠ CAUTION** Verify the chemical compatibility of the pump wetted parts and the substance being pumped, flushed or recirculated. Chemical compatibility may change with temperature and concentration of the chemical(s) within the substances being pumped, flushed or circulated. For specific fluid compatibility, consult the chemical manufacturer.

**⚠ CAUTION** Maximum temperatures are based on mechanical stress only. Certain chemicals will significantly reduce maximum safe operating temperature. Consult the chemical manufacturer for chemical compatibility and temperature limits. Refer to PUMP DATA on page 1 of this manual.

**⚠ CAUTION** Be certain all operators of this equipment have been trained for safe working practices, understand its limitations, and wear safety goggles / equipment when required.

**⚠ CAUTION** Do not use the pump for the structural support of the piping system. Be certain the system components are properly supported to prevent stress on the pump parts.

- Suction and discharge connections should be flexible connections (such as hose), not rigid piped, and should be compatible with the substance being pumped.

**⚠ CAUTION** Prevent unnecessary damage to the pump. Do not allow pump to operate when out of material for long periods of time.

- Disconnect air line from pump when system sits idle for long periods of time.

**⚠ CAUTION** Use only genuine replacement parts to assure compatible pressure rating and longest service life

**NOTICE** Replacement warning labels are available upon request: Static Spark PN \ 93122 & Diaphragm Rupture PN \ 93616-1.

**NOTICE** RE-TORQUE ALL FASTENERS BEFORE OPERATION. Creep of housing and gasket materials may cause fasteners to loosen. Re-torque all fasteners to insure against fluid or air leakage.

<b>⚠ WARNING</b>	= Hazards or unsafe practices which could result in severe personal injury, death or substantial property damage.
<b>⚠ CAUTION</b>	= Hazards or unsafe practices which could result in minor personal injury, product or property damage.
<b>NOTICE</b>	= Important installation, operation or maintenance information.



---

## AIR AND LUBE REQUIREMENTS

---

**⚠ WARNING** **EXCESSIVE AIR PRESSURE. Can cause pump damage, personal injury or property damage.**

- A filter capable of filtering out particles larger than 50 microns should be used on the air supply. There is no lubrication required other than the ring lubricant which is applied during assembly or repair.
- If lubricated air is present, make sure that is compatible with the Nitrile rings in the air motor section of the pump.

---

## OPERATING INSTRUCTIONS

---

- Always flush the pump with a solvent compatible with the material being pumped if the material being pumped is subject to setting up when not in use for a period of time.
- Disconnect the air supply from the pump if it is to be inactive for a few hours.
- The outlet material volume is governed not only by the air supply but also by the material supply available at the inlet. The material supply tubing should not be too small or restrictive. Be sure not to use hose which might collapse.
- When the diaphragm pump is used in a forced-feed (flooded inlet) situation, it is recommended that a Check Valve be installed at the air inlet.
- Secure the diaphragm pump legs to a suitable surface to insure against damage by vibration.

---

## MAINTENANCE

---

Refer to the part views and descriptions as provided on page 4 through 9 for parts identification and service kit information.

- Certain Smart Parts are indicated which should be available for fast repair and reduction of down time.
- Service kits are divided to service two separate diaphragm pump functions: 1. AIR SECTION, 2. FLUID SECTION. The FLUID SECTION is divided further to match typical part MATERIAL OPTIONS.
- Provide a clean work surface to protect sensitive internal moving parts from contamination from dirt and foreign matter during service disassembly and reassembly.
- Keep good records of service activity and include pump in preventive maintenance program.
- Before disassembling empty captured material in the outlet manifold by turning the pump upside down to drain material from the pump.

---

## FLUID SECTION DISASSEMBLY

---

1. Remove the manifolds (14). See Figure 2.
2. Remove (15) balls, (16) O-rings, and (17) Seats. See Figure 2.
3. Remove the fluid caps (9). See Figure 2.

**NOTE:** Only PTFE diaphragm models use a primary diaphragm (5) and a backup diaphragm (4). See Figure 2.

4. Remove the (8) screws, (7) washers, (5) or (5/4) diaphragms, (3) washer, and (6) washer. See Figure 2.
5. Remove (2) "O" rings.

**NOTE:** Only PTFE diaphragm models use a primary diaphragm (5) and a backup diaphragm (4). See Figure 2

---

## FLUID SECTION REASSEMBLY

---

- Reassemble in reverse order.
- Clean and inspect all parts. Replace worn or damaged parts with new parts as required.
- Lubricate (1) diaphragm rod with white grease.
- Be certain (5) or (5/4) diaphragm(s) align properly with (9) fluid caps before making final torque adjustments on bolt and nuts to avoid twisting the diaphragm.
- For models with PTFE diaphragms: Item (4) santoprene diaphragm is installed with the side marked AIR SIDE towards the pump center body. Install the PTFE Diaphragm with the side marked FLUID SIDE towards the fluid cap.
- When reassemble (133) Y-type rings, Pay attention to the orientation of Y-type rings (133), Must ensure correct installation. See Figure 7.
- Re-check torque settings after pump has been restarted and run awhile.



# PARTS LIST / DP31-25AXXXXX FLUID SECTION

DP31-Flu25-XX FLUID SECTION KITS include: BALLS(see Ball Option), DIAPHRAGMS (see Diaphragm Option), plus item16, item 2, and white lubricating grease.

Position number	Description	Part number	Material	Quantity
1	Rod	NDA-PD77	SS304	1
2	O-Ring	Y328-14	PTFE	4
3	Washer-Air Side	93441-2	Electrophoretic Steel	2
4	Backer Diaphragm	92973-B	Santoprene(Green)	2
5	Diaphragm	90533-1	Neoprene	2
		90533-2	Nitrile	2
		90533-3	Viton	2
		93459-4	PTFE	2
		90533-9	Hytrel	2
		90533-B	Santoprene(Yellow)	2
6	Washer-Fluid Side	93441-1	Stainless Steel	2
7	Washer	NDA-PN70	Stainless Steel	2
8	Bolt M12x1.25x35	NDA-PX20	Stainless Steel	2
9	Fluid Cap	94945	Aluminum	2
		97615	Stainless Steel ANSI 316	2
		94277	Cast Iron	2
10	Nut M8	NDA-PX11	Steel	16
		NDA-PX12	Stainless Steel	16
11	Bolt M8x40	NDA-PX23	Steel	16
		NDA-PX24	Stainless Steel	16
12	Bolt M8x25	NDA-PX25	Steel	8
		NDA-PX26	Stainless Steel	8
	Bolt (5/16" -18 x1")	Y6-55-T	Stainless Steel	8
13	Leg	NDA-PN119	Steel	2
		NDA-PN118	Stainless Steel	2
14	Manifold	92001 (NPTF)	Aluminum	2
		92001-1(BSP)	Aluminum	2
		91044 (NPTF)	Stainless Steel ANSI 316	2
		91044-1(BSP)	Stainless Steel ANSI 316	2
		94278 (NPTF)	Cast Iron	2
		94278-1(BSP)	Cast Iron	2
15	Ball (25.4mm dia.)	90532-1	Neoprene	4
		90532-2	Nitrile	4
		90532-3	Viton	4
		90532-4	PTFE	4
		90532-8	Polyurethane	4
		90532-C	Hytrel	4
		90948	Stainless Steel ANSI 316	4
		90532-A	Santoprene(Yellow)	4
16	O-Ring 34.6*2.7 (ID*Sec)	Y325-126	Nitrile	4
		Y327-126	Viton	4
		Y328-126	PTFE	4
		90534	E.P.R.	4
17	Seat	92008-1	Aluminum	4
		90428-1	Stainless Steel ANSI 316	4
		92926	Polyurethane	4
		95675-1	Carbon Steel	4
18	1" Plastic Plug	NDA-PU01	Plastic	2
19	1/4" Plastic Plug	NDA-PU11	Plastic	1

NOTE: Only PTFE diaphragm models use a primary diaphragm (5) and a backup diaphragm (4).



# PARTS LIST / DP31-25AXXXXXX FLUID SECTION

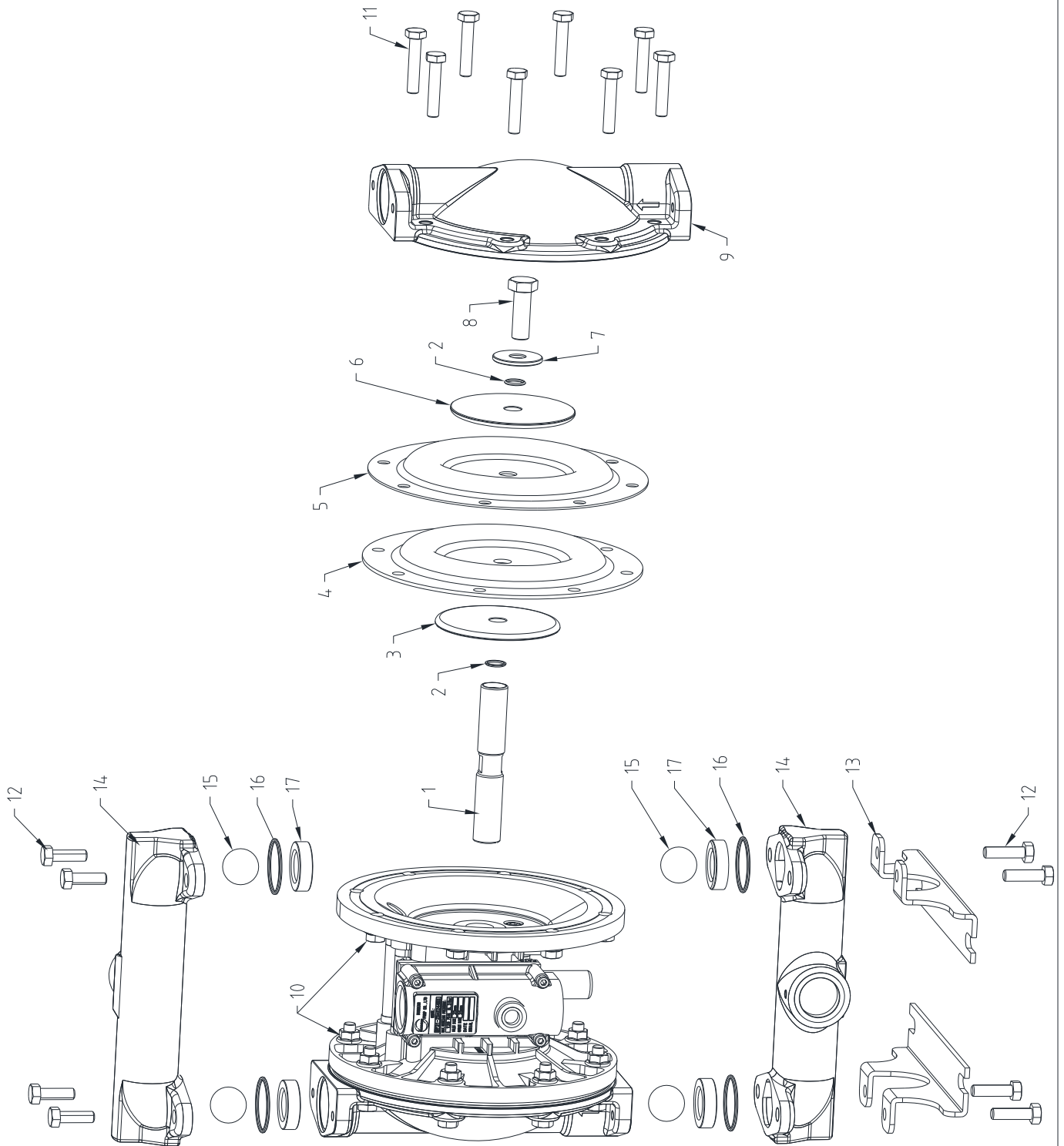

Figure 2



# AIR MOTOR SECTION SERVICE

Service is divided into two parts- 1. Pilot Valve, 2. Major Valve  
**GENERAL REASSEMBLY NOTES:**

- Air Motor Section Service is continued from Fluid Section repair.
- Inspect and replace old parts with new parts as necessary. Look for deep scratches on surfaces, and nicks or cuts in “O”rings and Y-type rings.
- Take precautions to prevent cutting “O”rings and Y-type rings upon installation.
- Lubricate “O”rings and Y-type rings with lubricant grease.
- Do not overtighten fasteners, refer to torque specification block on view.
- Re-torque fasteners following restart.

## PILOT VALVE DISASSEMBLY

- 1.Remove (112)Screws, and (166)major valve. See figure 3.
- 2.Remove (113), (114) , (115) , (116) , (117) , (118) , (119) , (120) , (121) .See figure 3.

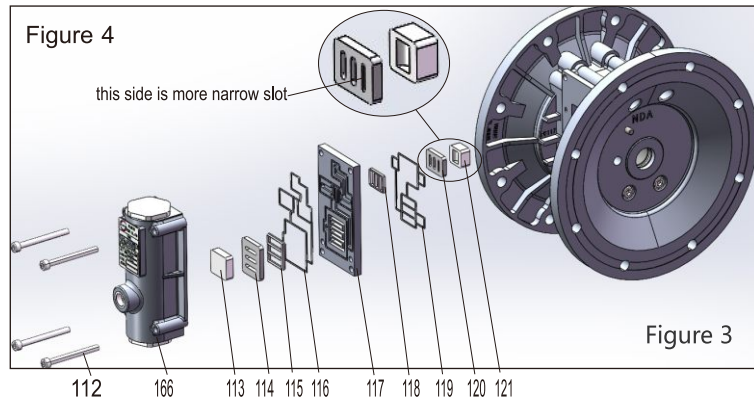

- 3.Remove (136), (134), (138), and (131). See figure 4.
- 4.Remove (132) sleeves from (123) center block,and remove (133) Y-type rings from (134) & (138). See figure 5.
- 5.Remove(128), (129), and (130). See figure 4.
- 6.Remove (127)and (126). See figure 4.
- 7.Remove (125) and (124). See figure 4.

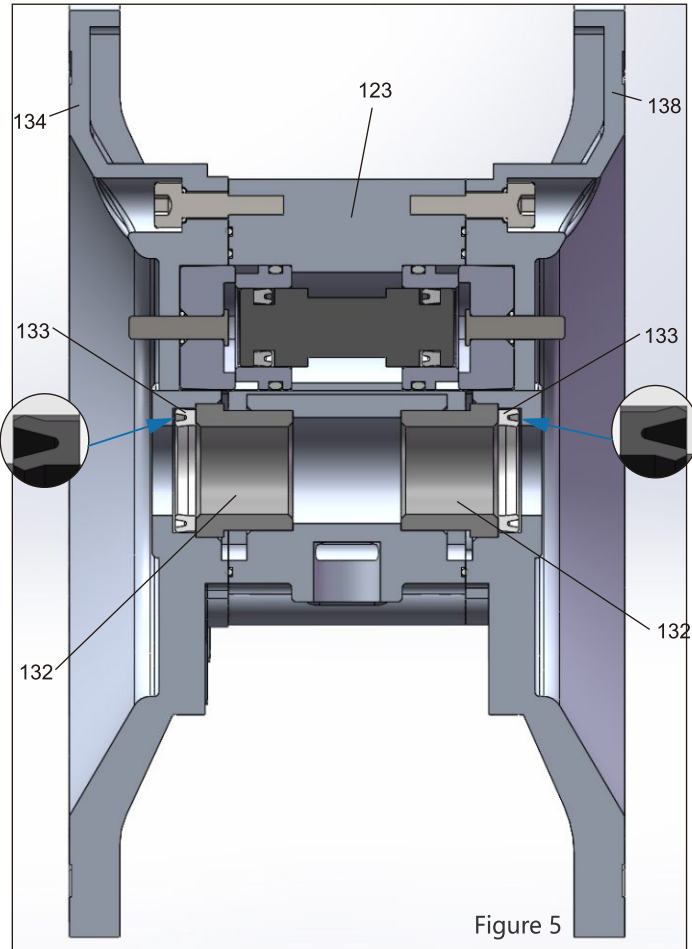
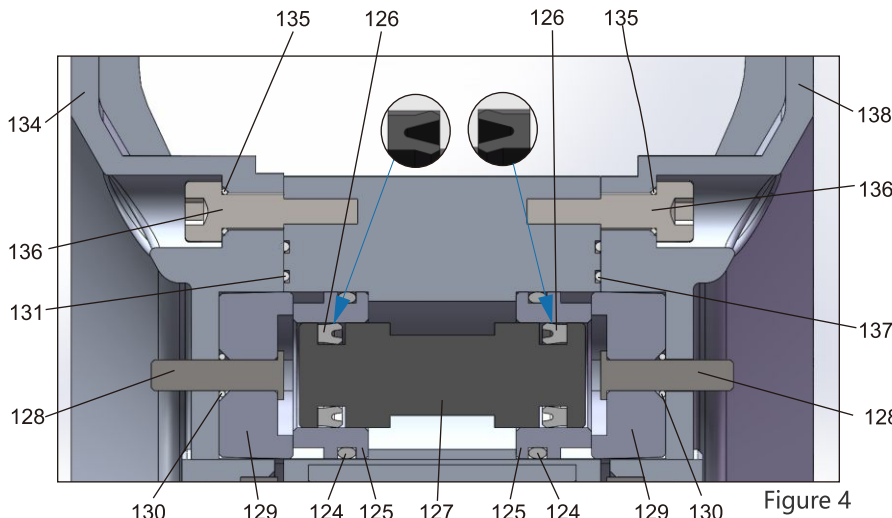

## PILOT VALVE REASSEMBLY

1. Replace all o-rings,Y-type rings and gaskets if worn or damaged. These are (115),(116),(118),(119),(135), (131),(130),(124), and (126).
2. Look for deep scratches or damages on sealing surfaces of (113) and (114). If there are scratches or damages , Replace them.

**Note:** (113) and (114) are not included in Air Section Repair Kit, but Keep them on hand in addition to the Service Kits for fast repair and reduction of down time.

3. Look for deep scratches or damages on sealing surfaces of (120) and (121). If there are scratches or damages , Replace them.

**Note:** (120) and (121) are not included in Air Section Repair Kit, but Keep them on hand in addition to the Service Kits for fast repair and reduction of down time.

4. Reassemble in reverse order.

**Note:**

- In the process of reassembly, be careful and not brutal.
- Lubricate all o-rings and Y-type rings with lubricant grease.
- Lubricate the sealing surfaces with lubricant grease, where (113) and (114) contact with each other.
- Lubricate the sealing surfaces with lubricant grease, where (120) and (121) contact with each other.
- Pay attention to the orientation of (120) . Must ensure correct installation.
- Lubricate (128) with lubricant grease.
- Pay attention to the orientation of Y-type rings (126) & (133), Must ensure correct installation.

## MAJOR VALVE DISASSEMBLY

1. Remove (112) screws, then remove the assembly of major valve.
2. Remove (113) and (114).
3. Remove (103) by wrench.
4. Remove (107) and (106) together.
5. Remove (102) using a circlip pliers.
6. Remove (109), then remove (111).
7. Remove (105) Y-type ring from (106); Remove (108) Y-type ring from (107), and remove (104) O-rings from (103).
8. Remove (140) O-ring from (110).

## MAJOR VALVE REASSEMBLY

1. Replace all o-rings, Y-type rings and gaskets if worn or damaged. These are (105), (108), (104), and (140).
2. Look for deep scratches or damages on the sealing surfaces of (113) and (114). If there are scratches or damages, Replace them.  
**Note:** (113) and (114) are not included in Air Section Repair Kit, but Keep them on hand in addition to the Service Kits for fast repair and reduction of down time.
3. Reassemble in reverse order.

### Note:

- In the process of reassembly, be careful and not brutal.
- Lubricate all o-rings and Y-type rings with lubricant grease.
- Lubricate the sealing surfaces with lubricant grease, where (113) and (114) contact with each other.
- Pay attention to the orientation of Y-type rings (105) & (108). Must ensure correct installation.
- Pay attention to the orientation of (113). Must ensure correct installation.

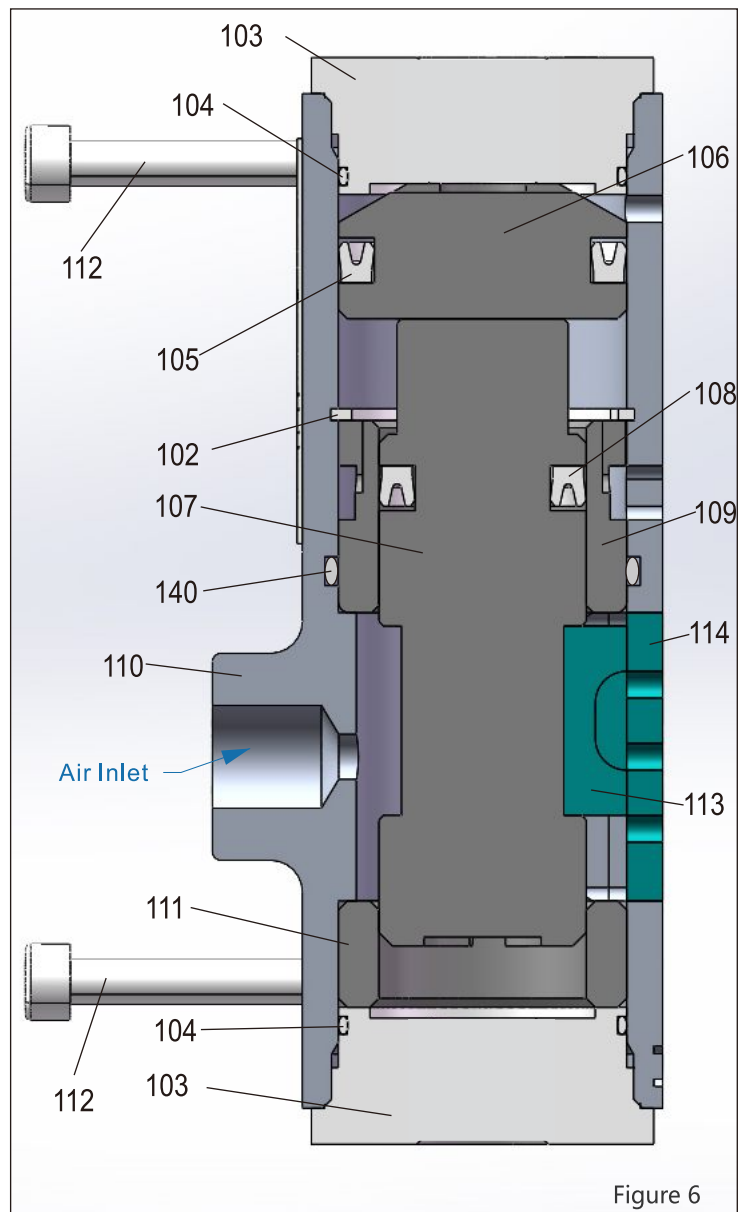

Figure 6



# PARTS LIST / DP31-25AXXXXX AIR MOTOR SECTION

Position number	Description	Part number	Material	Quantity
102	Retaining Ring 32	NDA-PN120	Stainless Steel	1
103	Valve Cap	NDA-PJ69	Aluminum	2
104	O-Ring 30*1.5 (ID*Sec)	NDA-PY27	Nitrile	2
105	Y Type Seal 32*24*4.5	NDA-PW22	Nitrile	1
106	Piston	NDA-PK141	POM	1
107	Spool	NDA-PK142	POM	1
108	Y Type Seal 23*15*4.5	NDA-PW29	Nitrile	1
109	Guide Bush	NDA-PK143	POM	1
110	Valve Body	NDA-PI69	Aluminum	1
111	Guide Bush	NDA-PK144	POM	1
112	Screw M5*50	NDA-PX72	Steel	4
		NDA-PX73	Stainless Steel	4
113	Bigger Valve Insert	NDA-PK168	Ceramic	1
114	Bigger Valve Plate	NDA-PK169	Ceramic	1
115	Gasket	NDA-PK170	Nitrile	1
116	Gasket	NDA-PK171	Nitrile	1
117	Adapter Plate	NDA-PK172	Aluminum	1
118	Gasket	NDA-PK173	Nitrile	1
119	Gasket	NDA-PK174	Nitrile	1
120	Valve Plate	NDA-PK175	Ceramic	1
121	Valve Insert	NDA-PK176	Ceramic	1
122	Nut M5	NDA-PX74	Steel	4
		NDA-PX75	Stainless Steel	4
123	Pump Body	NDA-PA70	Aluminum	1
124	O-Ring 22*2.5 (ID*Sec)	NDA-PY28	Nitrile	2
125	Guide Bush	NDA-PK177	POM	2
126	Y Type Seal 17*10*4	NDA-PW30	Nitrile	2
127	Spool	NDA-PK178	POM	1
128	Pilot Pin	NDA-PK179	Stainless Steel	2
129	Retainer Ring	NDA-PK180	POM	2
130	O-Ring 5*1.5 (ID*Sec)	NDA-PY16	Nitrile	2
131	Gasket	NDA-PF88	Nitrile	1
132	Bush	NDA-PG71	POM	2
133	Y Type Seal 27*19*4.5	NDA-PW31	Nitrile	2
134	Left Air Cap	NDA-PB117	Aluminum	1
135	O-Ring 6*1.5 (ID*Sec)	NDA-PY29	Nitrile	8
136	Screw M6*25	NDA-PX76	Steel	8
		NDA-PX77	Stainless Steel	8
137	Gasket	NDA-PF89	Nitrile	1
138	Right Air Cap	NDA-PB118	Aluminum	1
139	Muffler	93110	Assembly	1
140	O-Ring 32*2 (ID*Sec)	NDA-PY30	Nitrile	1



# PARTS LIST / DP31-25AXXXXXX AIR MOTOR SECTION

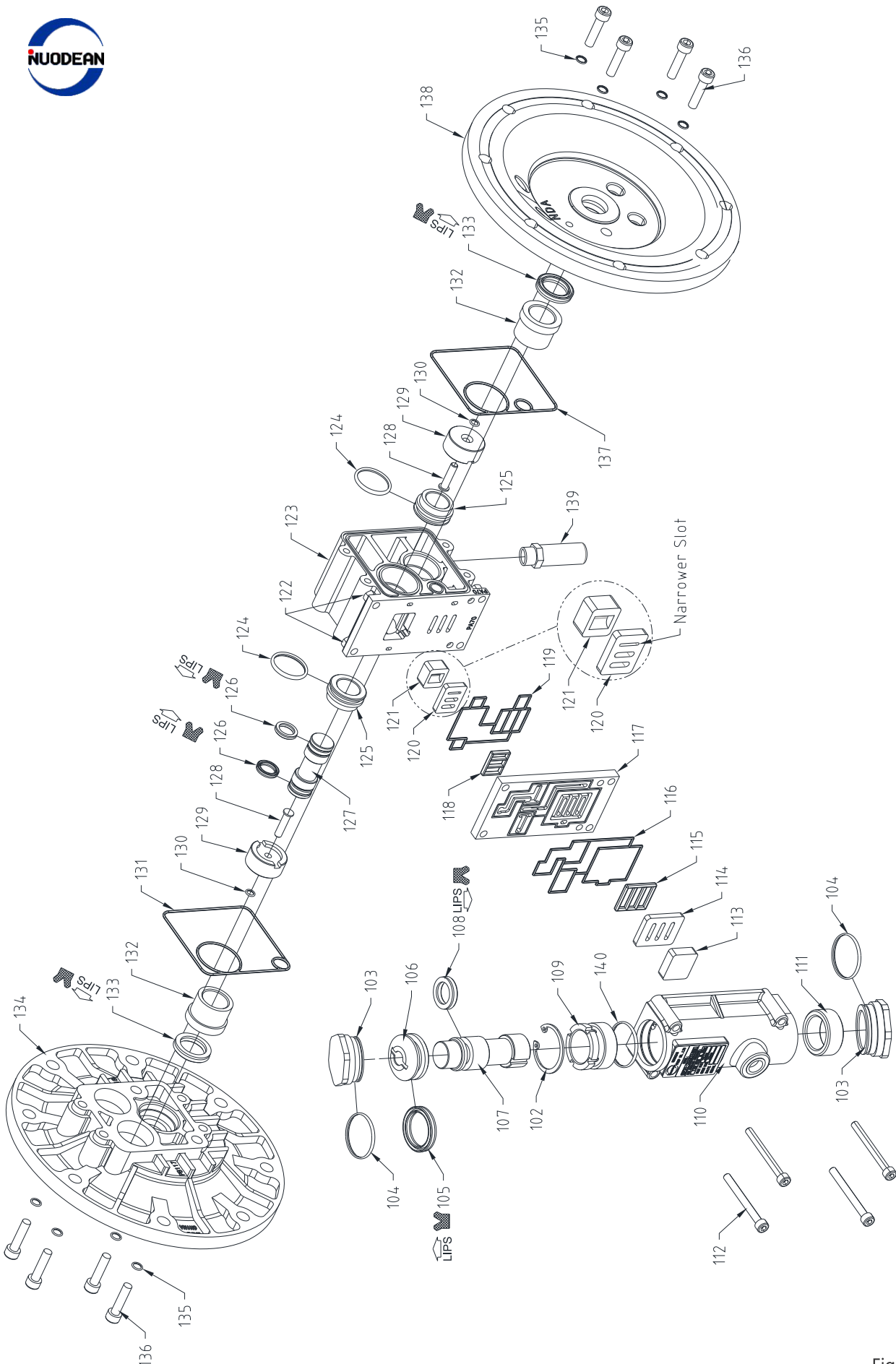

Figure 7

# TROUBLE SHOOTING

## Product discharged from exhaust outlet

- Check for diaphragm rupture.
- Check tightness of diaphragm nut.

## Air bubbles in product discharge.

- Check connections of suction plumbing.
- Check o-rings between intake manifold and fluid caps.
- Check tightness of diaphragm nut.

## Low output volume, erratic flow, or no flow.

- Check air supply.
- Check for plugged outlet hose.
- Check for kinked (restrictive) outlet material hose.
- Check for kinked (restrictive) or collapsed inlet material hose.
- Check for pump cavitation—suction pipe should be sized at least as large as the inlet thread diameter of the pump for proper flow if high viscosity fluids are being pumped. Suction hose must be a non-collapsing type, capable of pulling a high vacuum.
- Check all joints on the inlet manifolds and suction connections. These must be air tight.
- Inspect the pump for solid objects lodged in the diaphragm chamber or the seat area.

# DIMENSIONAL DATA

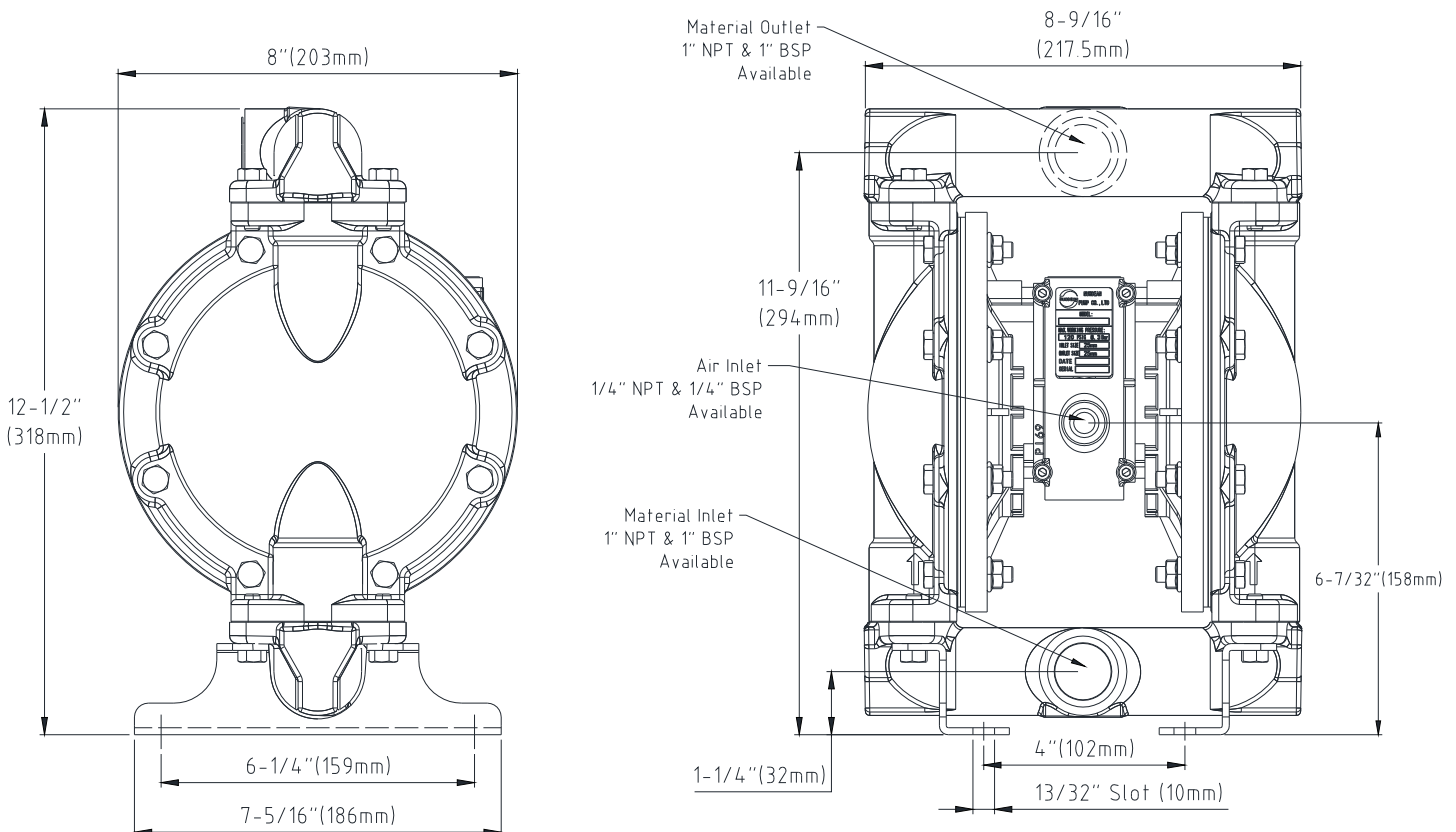

Dimensions shown are for reference only, they are displayed in inches and millimeters (mm).

